



LIVE THE BRAAI LIFE

## SAFARI CHEF 30

MODEL No: 6540HO & 6540HI

High Pressure



MODEL No: 6540HI



MODEL No: 6540HO



1002-137/2-RSA-17-A

# USER INSTRUCTIONS

GB DE DK ES FR IT NL NO PL SE SI FI

NOTE! PRODUCT MAY VARY FROM ILLUSTRATIONS - FOR PICTORIAL PURPOSES ONLY!

503-0454 LEV22

## CAUTION

For Outdoor use only!



This appliance may not be used in an exterior enclosed balcony, porch or entertainment area!

## IMPORTANT

Read these instructions for use carefully so as to familiarize yourself with the appliance before connecting it to its gas container. Keep these instructions for future reference.

### 1. General information

- This appliance has been designed to be used for outdoor cooking, specifically for people who go camping to enjoy outdoor life and it can also be used at home on your patio.
- Various food types can be prepared on this appliance. The Safari Chef is designed to utilise various cooking surfaces.
- Gas is supplied to the unit via a disposable cartridge. A high pressure hose and regulator can be connected to gas a cylinder, (South Africa ONLY - Not Supplied with the appliance)
- The unit is easy to switch on, and to operate (Section 6) and the user can control the heat input with an adjustable valve.
- The unit is supplied with a convenient carry bag.
- This appliance complies with EN521:2019 and SANS 1539:2017.
- This appliance may only be used with a CADAC 500g, 445g, or 220g Disposable Threaded Resealable Gas Cartridge (Model CA500, CA445 or CA220) or the same type threaded resealable cartridges complying with EN417
- The gas supply is to be used only in an upright position.
- Warning:** Accessible parts may be very hot. Keep young children away.
- Gas appliances require ventilation for efficient performance and to ensure the safety of users and other persons in close proximity, therefore do not use the appliance in an unventilated area. It is intended for use outdoors only. Read these instructions carefully before using the appliance.
- Use outdoors only!**

6540H0, 6540H1				
Country of Use	BE, CH, CY, CZ, ES, FR, GB, GR, IE, IT, LT, LU, LV, PT, SK & SI	PL	BE, CY, DK, EE, FR, FI, HU, IT, LT, NL, NO, SE, SI, SK, RO, HR, TR, BG, IS, LU, MT, & ZA	AT, CH, DE & SK
Allowable gasses	Butane			
Gas Pressure	Vapour Pressure			
Jet Number	0.25			
Nominal Usage	132g/hr			
Gross nom. heat input	1.82kW			

Country Name and Abbreviations				
AE = United Arab Emirates	AL = Albania	AT = Austria	BE = Belgium	CH = Switzerland
CZ = Czech Republic	DE = Germany	DK = Denmark	ES = Spain	FI = Finland
FR = France	GB = United Kingdom	GR = Greece	HR = Croatia	IT = Italy
JP = Japan	KR = Korea	NL = Netherlands	NO = Norway	PL = Poland
PT = Portugal	RO = Romania	RU = Russia	RS = Serbia	SI = Slovenia
SK = Slovakia	SE = Sweden	TR = Turkey	ZA = South Africa	

### 2. Safety Information

- Do not use the appliance if it has damaged or worn seals. Always operate the appliance on a firm level surface.
- Do not use an appliance that is leaking, damaged or which does not operate properly.
- This appliance must be kept away from flammable materials during use. Minimum safe distances are: Above the appliance 1.2m. At the rear and sides 600mm. (See Fig. 2)
- Ensure that the gas container is fitted or changed outdoors, away from any sources of ignition, such as naked flames, pilots, electric fires and away from other people.
- Keep gas containers away from heat and flame. Do not place on a stove or any other hot surface.
- Ensure that the assembled product is stable and does not rock.
- In the event of light back (where the flame burns back and ignites at the jet), immediately turn off the gas supply by closing the control valve on the appliance valve. After the flame has extinguished, remove the cartridge and check the condition of the seal. Should the flame persistently light back, return the product to your authorised CADAC repair agent.
- If there is a leak on your appliance (smell of gas), close the appliance valve immediately, and take it into a flame free location where the leak may be detected and stopped. If you wish to check for leaks on your appliance, do it outside. Do not try to detect leaks using a flame; use soapy water.

- The correct way is to smear the joints e.g. where the cartridge screws onto the appliance, with soapy water.
- If bubbles form, then there is a gas leak. Immediately remove the gas cartridge from the appliance. Check that all the connections are properly fitted. Check that the seal is in place and in good condition before connecting a gas cartridge (Fig. 3c). Re-check with soapy water after refitting the cartridge.
- If a gas leak persists, return the product to your CADAC dealer for inspection / repair.
- **Use Outdoors Only.**

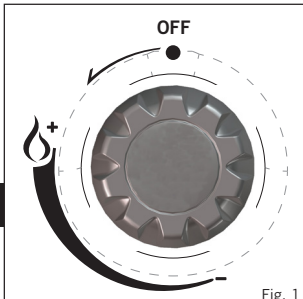

Fig. 1

### 3. Assembly Instructions

- **WARNING:** The legs are spring loaded. Opening and closing of the legs must be done in a controlled manner to avoid personal injury or damage to your Safari Chef.
- To open the legs, turn the unit upside-down and hold the legs down while lifting each leg individually (Fig. 4c). You will hear a "click" if the leg(s) has located correctly (Fig. 4a).
- To fold the legs back, securely hold the leg and push the leg release clip down (Fig. 4b). Then push the legs in-ward to its closed position (Fig. 4c). This needs to be done sequentially to optimize space. First the right front leg (1), then the left front leg (2), and lastly the rear leg (3) (as seen in Fig. 4d).
- Before connecting the gas supply, firstly check that the appliance valve is in the off position by turning the control knob fully clockwise (See Fig. 1). Making sure that the gas cartridge is kept upright, screw the cartridge into the valve in a clockwise direction until it is fully engaged (Fig. 3a), hand-tighten only. If the cartridge is overtightened, it may damage the cartridge valve.
- Your appliance is now ready for use.

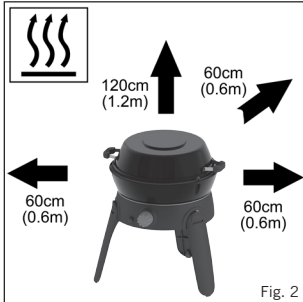

Fig. 2



Fig. 4a

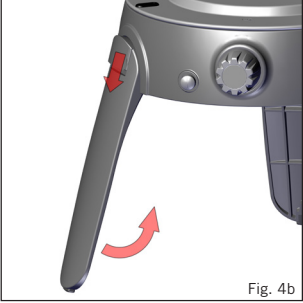

Fig. 4b



Fig. 3a

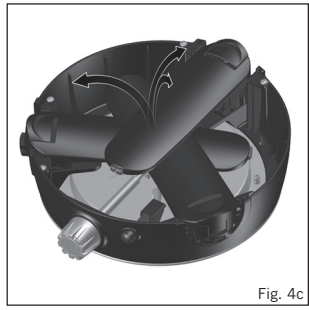

Fig. 4c

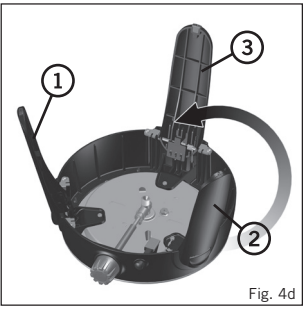

Fig. 4d

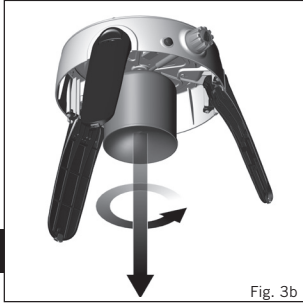

Fig. 3b

### 4. Fitting and Changing the Gas Supply

- Check that the burner is extinguished before disconnecting the gas cartridge.
- To disconnect the gas cartridge, unscrew the cartridge in a counter clockwise direction from the valve keeping the appliance in vertical position. (See Fig 3b)
- Check the seal before replacing the gas container (Fig. 3c).
- Change the gas cartridge outdoors and away from other people.
- To refit a previously used gas cartridge, refer to instructions in Section 3 above. Apply the same care and checking procedures as if fitting a new gas cartridge.

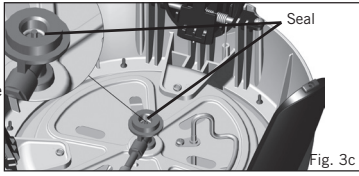

Fig. 3c

## 5. Component List

	A	B	C	D	E	F	G	H	I	J
6540H0-10		*	*	*		*	*			*
6540H1-10		*	*	*		*	*		*	*
6540H1-20		*	*			*	*		*	*
6540H1-21		*			*	*	*		*	*
6540H1-25	*	*	*	*		*	*	*	*	*

Item H - Quick Release - Not shown for high pressure model



## 6. Using the Appliance

- This appliance must be used outdoors only!
- When in use, protect from wind for optimum performance.
- Do not move the unit whilst hot. The use of protective gloves is recommended.
- **CAUTION:** Do not subject the non-stick cooking surfaces without food on / in it for extended periods as the heat may damage the non-stick coatings.
- **CAUTION:** Accessible parts may become very hot. Keep young children away from the appliance.
- To pack away, let the unit cool. After cleaning, fold the legs of the appliance as described in section 3 above. Place the pot / dome at the bottom of the bag. Next, place the pot stand upside down into the pot / dome. Place the fat pan upside down over the pot and pot stand. Then place the appliance upside down onto the fat pan. Place the grid and flat pan into their separate holders located in the lid of the bag and zip them closed. Fold over the lid of the bag, and zip it closed. (Fig. 5)
- Keep the appliance in its Carry Bag when not in use, as this will prevent the ingress of dirt or insects which may affect the gas flow.

- When attempting to light the appliance, make sure that the gas cartridge is properly fitted before turning on the gas supply to the appliance.
- To light the appliance using the piezo ignition, open the control valve on the appliance by slowly turning it in an anti-clockwise direction and press the piezo button in rapid succession to ignite the burner. If the burner fails to ignite, press the piezo button again continuously whilst increasing the gas flow by turning the control knob until the burner ignites. If the burner does not ignite in the first 5 seconds, close the valve and wait 30 seconds before trying again.
- To light the appliance manually, apply a flame to the burner using a BBQ Lighter, turn the appliance control knob slowly in an anti-clockwise direction until the burner lights (Fig. 1).
- Use the control knob to adjust the flame intensity to the desired level by turning the knob clockwise to decrease the flame and anti-clockwise to increase the flame.
- When not in use remove the gas cartridge.
- **WARNING:** Do not use any cooking surfaces on a high flame setting for more than 10 minutes as this can damage the non-stick coatings.

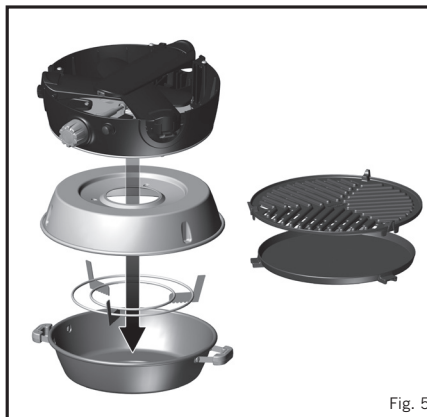

Fig. 5

## 7. Cooking Options

- There are five available cooking options (the 5th is an optional accessory) with your Safari Chef appliance. These are:  
**Barbecuing:** This cooking option is ideal for fat-free barbecuing of chicken, sausages, chops, kebabs, fish or vegetables. For this type of cooking, place the fat pan onto the heat shield. Place the BBQ grid onto the locators of the fat pan.

**Caution:** Please note that when cooking fatty meats some fat will drip onto the unit which may cause flare-ups. Please use caution when handling such meats. The cooking temperatures are easily adjusted to suit your own requirements by turning the control knob to regulate the degree of heat.

**Frying:** This option is ideal for stir-fries, fish, breakfast, pancakes, prawns, paella and vegetables. For this type of cooking, place the fat pan onto the locators of the fat pan. Please note that being a shallow pan, it is not suitable for deep-frying. The easy clean surface encourages the minimum use of fat for healthy cooking.

**Oven Dome / Wok:** The dome can be used as a wok, a lid to create an oven on the BBQ, or a saucepan. For wok-style cooking, place the dome upside-down directly onto the pot stand and use to prepare stir-fries, pasta dishes or paella. To use the dome as an oven lid place the dome over a meal cooking on the BBQ option for convection style cooking. This is ideal for roasting chicken, lamb, beef or pork. The dome can also be used as a saucepan, to heat sauces, marinades, boil water, cook rice, pasta etc. Place the dome upside-down directly onto the pot stand.

**Boiling:** For this type of cooking, place the pot stand in its locator grooves on the heat shield ensuring that it is properly seated. Place a suitable pot (not less than 150mm diameter and not more than 300mm diameter) or the Safari Chef dome on the pot stand. The fat pan is designed to be placed onto the dome to act as a lid for the dome to boil food. One litre of water will boil in approximately 6 minutes depending on the conditions, size of pot used, etc. Note: When using small sized pots do not attempt to use pots with plastic handles. Pot stand can also be used in the fat pan.

**Pizza Baking (Optional Accessory):** For this type of cooking, place the pot stand into the fat pan. The fat pan has been designed in such a way that it can also be used as a windshield. Place the pizza stone onto the pot stand. Pre-heat your pizza stone before use. Ensure that food is at room temperature before placing it onto the pizza stone, **DO NOT** put frozen food onto a heated pizza stone. Put the dome on to create an oven effect for better heat distribution. For cooking methods when using the pizza stone, please refer to the pizza stone user manual.

### Barbecuing



### Frying



### Oven Dome / Wok



### Boiling



### Pizza Baking



## 8. Cleaning

### BBQ Unit

- To clean the fat pan, flat pan, and BBQ grid, wash in warm water with a non-abrasive detergent after first wiping off any excess fat left after cooking.
- To clean the dome, wash in warm water with a non-abrasive detergent.
- Do not use an abrasive cleaner on any part, as this will damage its surface coating.
- These parts are perfectly safe to clean in the dishwasher after removing any excess fat.

### Body / Leg Unit

- This is best cleaned by using a soft damp cloth and a mild non-abrasive detergent. Do not place in a dishwasher as this may allow water into the valve or burner ports, which will cause the unit to malfunction.
- When cleaning the body/leg unit the pot stand may need to be removed. This can be done lifting the pot stand out of the locator groove in the heat shield.

## 9. General Maintenance

- The onus of maintaining this appliance solely rests on the consumer from date of purchase.
- This appliance does not require scheduled maintenance.
- After prolonged storage, inspect the air holes under the unit and the inlet of the venturi for insects such as spiders, etc which could affect gas flow. After checking, refit all components into the prescribed position.

### Replacing a Blocked Jet:

- Your Safari Chef is fitted with a specific size jet to regulate the correct amount of gas.
- Should the hole in the jet become blocked, this may result in a small flame or no flame at all. Do not attempt to clean the jet with a pin or other such device as this may damage the orifice, which could make the appliance unsafe.
- **To replace the jet:** Remove the fat pan (Fig. 6). Gently unscrew the burner assembly (Fig. 7). Remove the three screws from the heat shield plate and remove the heat shield (Fig. 8), **taking care not to damage the piezo electrode.** The jet can now be removed using a suitable spanner (Fig. 9). Do not use pliers on the jet as this may damage the jet, making it unusable or impossible to remove. Screw the new jet into the valve. Do not over-tighten as this may damage the jet.
- Reverse the above procedure to re-assemble the unit.



Fig. 6



Fig. 7

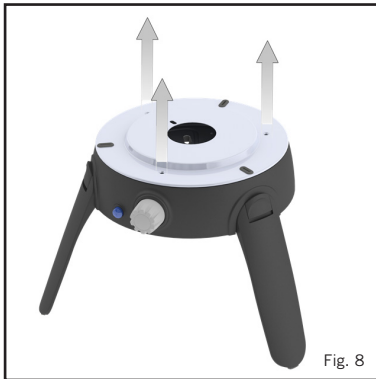

Fig. 8

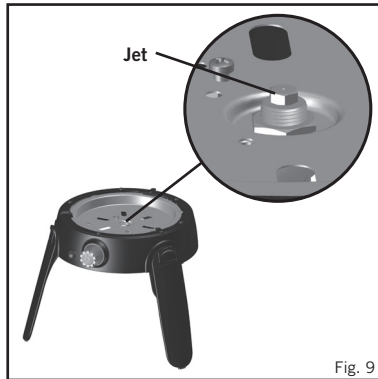























Fig. 9

## 10. Returning the appliance for repair or service.

- Do not modify the appliance, as this could be dangerous.
- If you cannot rectify a fault by following these instructions, contact your local CADAC distributor for details on how to return the product for attention.
- Your CADAC Safari Chef is guaranteed by CADAC for a period of 2 years against factory fault.

## 11. Spares and Accessories

- Always use genuine CADAC spares as they have been designed to give optimum performance.

Spares		Accessories	
Item	Spare No.	Item	Spare No.
	6540-SP011		6540-SP056
	6540-SP020		6540-SP008
	6540-SP002		6540-SP015 (Jet 0.19 & valve [2014]) 6540-SP015-V2 (Jet 0.19 & valve [2015]) 6540-SP031 (Jet 0.25 [2015])
	6540-SP004		6540-SP055
	6540-SP003		<b>Front L &amp; R Leg</b> 6540-SP010
	6540-SP017		<b>Back Leg</b> 6540-SP009
	6540-SP018 (2014) 6540-SP018-V2 (2015 onwards)		
	6540-SP019		
			6540-300
			6540-100
			6540-200
			6540-600
			6540-700
			<b>Cover</b> (300 x 300mm) 6540-800
			8635
			6544-100



LIVE THE BRAAI LIFE

#### CADAC INTERNATIONAL

P.O. Box 43196,  
Industria, 2042 South Africa  
Tel: +27 11 470 6600  
Email: info@cadac.co.za  
www.cadacinternational.com

#### CADAC UK

14 Deanfield Court,  
Link59 Business Park,  
Clitheroe, Lancashire,  
BB7 1QS  
United Kingdom.  
Tel: +44 (0) 333 2000363  
E-mail: info@cadacuk.com  
www.cadacinternational.com

#### CADAC MOZAMBIQUE

Exclusive Brands Africa  
492 Avenida Namaacha  
Maputo, Mozambique  
Tel: +258 21 406254  
www.cadac.co.mz

#### CADAC IRAN

Robin Bazarganan Carin Co.  
Unit D, 6th Floor, Negin Zafar  
Building, No.1327,  
Shariati Street, Tehran, Iran  
Tel: +98 21 276 00 781  
Mail: info@cadac.ir

#### CADAC CHINA

Room 807, Huayue International  
Building, No.255 Tiangao Road,  
South  
Yinzhou business district,  
Ningbo, China  
Tel:+86 574 87723937  
Email: info@cadac.com.cn

#### CADAC SWEDEN & NORWAY

KAMA FRITID AB  
0046 36 353700  
info@kamafritid.se

#### CADAC EUROPE

Ratio 26, 6921 RW Duiven  
The Netherlands  
Tel: +31 26 319 7740  
Email: info@cadaceurope.com  
www.cadacinternational.com

#### CADAC SCANDINAVIA

Millarco International A/S  
Rokhøj 26  
8520 Lystrup, Denmark  
Phone: +45 87 43 42 00  
millarco@millarco.dk  
www.millarco.com

#### CADAC MONTENEGRO

City kvart Z1L6  
81000 Podgorica, Montenegro  
Tel 38220671446,  
38269020063  
E-mail: ccca@t-com.me

#### CADAC DENMARK

Camper Fritid  
Industrivej 11  
6640 Lunderskov, Denmark  
Tel.: +45 7558 5255  
Email: info@camper.dk  
www.camper.dk

#### CADAC ZIMBABWE

Exclusive Brands Africa  
Unit 8 Birkenhead Park  
43 Josiah Chinamano Street  
Belmont, Bulawayo  
Tel: +263 971 740 (Bul)  
Tel: +263 479 2564 (Har)  
www.cadac.co.zw

#### CADAC GERMANY

Ratio 26, 6921 RW Duiven  
The Netherlands  
Tel: +31 26 319 7740  
Email: info@cadaceurope.com  
www.cadacinternational.com

#### CADAC Czech Rep.

RÖSLER Praha spol. s r.o.  
K Horkám 19/21  
102 00 Praha 10 Česká republika  
Tel: +420 267 188 011  
Email: info@rosler.cz  
www.rosler.cz

#### CADAC FINLAND

OY KAMA FRITID AB  
Koivuhaantie 2-4 B  
01510 VANTAA  
00358 20 792 0310  
info@kamafritid.fi

#### CADAC POLAND

Kamai  
Wola Batorska 461  
32-007 Wola Batorska Poland  
Tel: +48 12 635 1373  
Email: handlowy@kamai.pl  
www.kamai.pl

#### CADAC ZAMBIA

Exclusive Brands Africa Limited  
7225A Kachidza Road  
Light Industrial Area  
Lusaka, Zambia  
Tel: +260 211 842015  
Tel: +260977 345034  
Email: info@ebagrp.com

#### CADAC FRANCE

Le Viallon, 42520 Veranne  
France  
Tel: +33 4 74 78 13 65  
Email : info@cadaceurope.com  
www.cadacinternational.com

#### CADAC NEW ZEALAND

Riverlea Group (Pty) Ltd  
2A Maui Street, Pukete,  
Hamilton 3200, New Zealand  
Tel: +64 7 847 0204  
Email: sales@riverleagroup.co.nz  
www.riverleagroup.co.nz

#### CADAC U.A.E.

Supreme Impex General Trading  
LLC Office No. 1801-7 Latifa  
Tower Sheikh Zayed Road  
Dubai, UAE

#### CADAC ITALY

Brunner SRL/GMBH  
via Buozzi, 8  
39100 Bolzano (Italy)  
Tel: +39 0471 542900  
Email: info@brunner.it  
www.brunnerinternational.com

#### CADAC SOUTH EAST EUROPE

Bulevar oslobodjenja 285  
Tel: +381 11 339 2700  
Email: sinisaj@cadac.rs  
www.cadac.rs

